Preface

Thank you for choosing 5kW Air parking heater.

This instruction book describes the structures, working principles, installation and operation of the air-heating parking heater. For correct use of the heater, please read this instruction book carefully before installation and use. The instruction book shall be saved in a convenient place for later reference.

Attention:

- This instruction book is subject to revision without notice, but the instruction book is in conformity to the purchased product.
- Our effort is to explain all questions the users may have through this instruction book. If you have any doubts or find anything incorrect in this instruction book, please contact our company directly.
- At first unpacking, please check the heater and its accessories against the packing list. Please contact the dealer immediately if any problem is found.
- If any trouble arises during application, please contact the Department of Marketing of our company or other customer service stations authorized by this company. We shall do our best to provide service to you.

CONTENTS

1	Introduction	3
2	Main Technical Specifications	3
3	Structures and Working Principles	4
4	Installation	9
5	Methods of Operation	21
6	Treatment of Usual Troubles	23
7	Precautions	25
8	Packing List	28

Note:

Comply with the operational manual for installation and use to ensure that the heaters can work for a long time.

Version No.:20151104

1 Introduction

The main equipment of Model 5KW air parking heater (hereinafter referred to as the heater) is a small fuel furnace controlled by a single-chip micro-processor. Its furnace body (the heat exchanger) is located in the hood-shape case, which serves as independent air passage. Cold air is sucked into the air passage by the heat supplying fan and blown out when it becomes hot, so as to form another heating system that is to the original heating system of the vehicles. In such a way, heat can be supplied by the heater to driver's cab and passengers' compartment no matter the engine is working or not working.

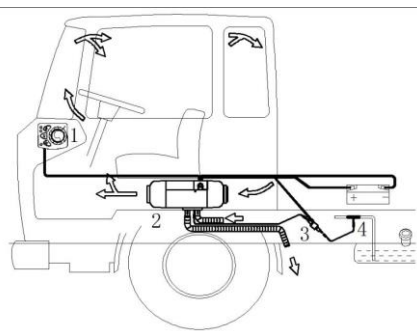

Fig. 1

The schematic diagram is shown in Fig. 1. 1-Control switch 2- Heater 3- Fuel pump 4- Reducing T 5- Fuse box

The heater is fully automatically controlled. It features in compact structure, easy installation, energy-saving, environmental protection, safety and reliability, easy maintenance, etc.

2 Main Technical Specifications

Please refer to Table 1 for main technical specifications.

Table 1

Heat Power (W)	5000	
Fuel	Gasoline	Diesel
Rated Voltage	12V/24V	
Fuel Consumption	0.19~0.66	0.19~0.60
Rated Power Consumption (W)	15~90	
Working (Environment) Temperature	-40℃~+20℃	
Working height above sea level	≤1500m	
Weight of Main Heater (kg)	5.9	
Dimensions (mm)	425×148×162	
Mobile phone control (Optional)	No limitation	
Remote control (Optional)	Without obstacles ≤800m	

3 Structures and Working Principles

The structures of the main heater are shown in Fig. 2

3.1 Combustion furnace

(includes combustion supporting fan blades and blade wheel of heating fan) 7-Screw 8- Seal of heat exchanger 9-Screw 10-Screw 11-Glow plug/Flame sensor 12-Pipe base 13-Guide pipe 14-Inlet of combustion supporting air 15- Blade wheel of heating fan 16-Fuel inlet pipe 17- Combustor core 18- Screw 19- Combustion pipe 20- Exhaust pipe vent 21- Insulating mat

3.2 Hood-Shape Case

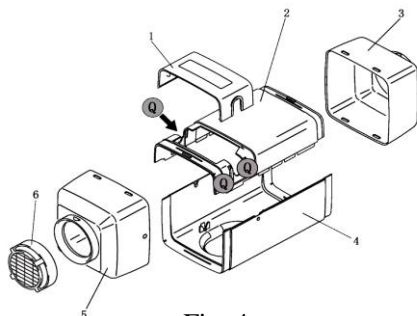

Fig. 4

1-Junction box cover 2-Top hood-shape cover 3-Hot air outlet
4-Bottom hood-shape cover 5-Air inlet of heater 6-Air inlet hood

The structure of the hood-shape case is shown in Fig. 4. It consists of the top cover 2 (The junction box cover 1 can be fixed on its window), bottom cover 4, air inlet hood 6, air inlet of heater 5 and hot air outlet 3. They form an air heating passage. Blade wheel of heating fan (Fig.3-6) on the fan motor (the same fan for supporting combustion) sucks in cold air from the air inlet. The air is heated by the heat exchanger and sent out from the hot air outlet.

3.3 Controller

The controller (Fig. 3-1) is at the front of the heater and the back of the blade wheel of heating fan. This controller mainly including collect the circuit and exam the temperature circuit of the signal of a single-chip microprocessor、drive circuit、frequency、rotational speed、voltage. Have the function of heating process automation、system surveillance automation、breakdown handling automation.

3.3.1 Control of Working Procedures

Adjustment and control on operational status are performed during the whole working cycle (start-operation-stop) of heater in terms of the rotation speed of fan motor, the frequencies of fuel pump, on-off of glow plug, to given time sequence and in consideration of the preset value and measured value of the temperature of the temperature control point, rotation speed of fan motor feedback signal、frequency of fuel pump, surface temperature

of the heat exchanger and other random parameters. 3.3.2 Locking Due to Troubles

3.3.2 Fault Locking

When the heater can not be ignited normally, or can not sustain normal combustion after ignition, or broken circuit or short-circuit occurs to the glow plug, fan motor, fuel pump, or various sensors and components, or in case of overheating or overhigh of heat exchanger temperature, abnormal of power voltage and speed of fan motor when heater operation, the heater will turn off and enter into locked status (unwork of glow plug, fuel pump and fan motor, LED light flashing on control switch) for protection.

3.3.3 Display of Troubles

For convenience of maintenance and repair, troubles of the heater can be identified by the controller and displayed by the indicators (green LED) of the control switch.

In trouble status, indicator light will flash circularly, each circulation include long indicator extinguishing (2 seconds) and a few times of (1.3Hz) slow flashes appear alternately. During the period between two long extinguishing, the times of slow flashes represent the types of troubles, as shown in Table 2.

Table 2

Times of flashes of LED	Cause of trouble
1	Failure of second start
2	Termination of the fifth time of combustion
3	Power voltage out of specified range
4	Furnace temperature overhigh during self-check period
5	Broken circuit or short-circuit of flame sensor
6	Broken circuit or short-circuit of temperature sensor
7	Broken circuit or short-circuit of fuel pump
8	Broken circuit, short-circuit, or rotation clogging of fan motor
9	Broken circuit or short-circuit of glow plug
10	Furnace body temperature overhigh or overheat before heater operation or temperature overhigh of overheat sensor or ambient temperature overhigh.
11	Broken circuit or short-circuit of overheating sensor
12	Broken circuit or short-circuit of control switch
13	Maintenance reminder: More than 800 hours of work time

3.3.4 Circuit Interfaces

The following circuit interfaces can be found on the controller case: X1 for fan motor, X2 for glow plug/flame sensor, X3 for overheating sensor, X4 for the leads to fuel pump, X5 for outer temperature sensor, X6 for compartment fan (extended function) and X7 for the main wire bundle. Please refer to Fig. 5 for their locations.

The connection parts are designed with such structures that wrong connection is made impossible.

3.4 Sensors and Safety Protection

3.4.1 Flame Sensor (also as Glow Plug)

This component has dual functions. When it is used as flame sensor, its characteristic of variable resistance with temperature is utilized to monitor the temperature of the furnace cavity. It is used to determine if the furnace is ignited in the ignition stage. In normal working condition, it is used to determine if the flame or combustion is continuing.

3.4.2 Overheating Sensor

The overheating sensor is installed on the middle of the outer wall of the heat exchanger. If the temperature here becomes higher than 182°C, the fuel pump circuit will be cut off by the controller and supply of fuel is stopped and then the heater is turned off for purpose of overheating protection.

3.4.3 Temperature Sensor

The internal temperature sensor (provide with the heater) is plugged into the heating air inlet. It measures the air temperature at the air inlet and changes the working status and output power of the combustion furnace based on the measured temperature.

Outside temperature sensor is optional parts which need to buy separately. This outside temperature sensor can be put into the heating position according to the need, its working principle same as the internal temperature sensor.

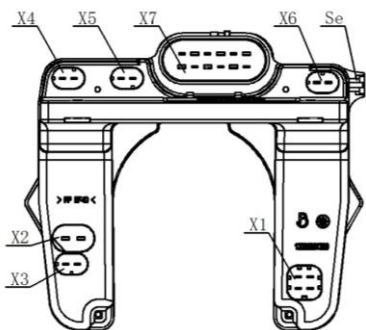

Fig. 5

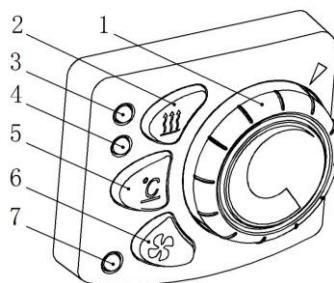

Fig. 6

- 1-Control Knob
- 2- Heating(constant power)mode button
- 3-Heating(constant power)indication light
- 4-Air conditioner(constant temperature) indication light
- 5- Air conditioner(constant temperature) mode button
- 6- Ventilation mode button 7-Ventilation indicating light

3.5 Control Switches

The control switch is shown in Fig. 6. Its control knob is used for the following operations: turning on or off of the heater and eliminating locking of the heater due to trouble interrupt and converting working mode through the mode conversion button.

Heating(constant power)mode:Press air conditioner(constant temperature) mode button then the heating(constant power)indication light turns yellow, use the control knob adjust heater power.(adjustable continuously between 1KW and 5KW).

Air conditioner(constant temperature) mode: Press Air conditioner(constant temperature) mode button then Air conditioner(constant temperature) indication light turns red,use the control knob to set the control temperature of the heated area(adjustable continuously from 5°C to 35°C).

Ventilation mode: Fan speed can be adjusted by control knob.

In running status, press the corresponding button which turns the indication light, shutdown heater and eliminate heater fault locking status. Push other unlighted buttons will switch to the corresponding work mode.

Constant lighting of the indicator on the control switch indicates normal operation of the heater. Flashing of the indicator indicates trouble status of the heater (see Section 3.3.3 for details).

3.6 Power Supply

Heater power leads (positive and negative line) must be connected to the 12 V/ 24 V battery directly. Battery more than 2 years which lack of electric frequently should be changed a new one in order to ensure normal use of the heater.

3.7 Fuel Supply

The fuel for the heater can be from the fuel tank in the car or from optional 5L independent fuel tank. The fuel pump is used for transmission of fuel and regulation of supply quantity of fuel.

4 Installation

Only special-purpose parts can be used for installation of the heater. Fig. 7 is the diagram for installation. The positions and ways of fixing of various parts may vary from one automobile model to another, but the general principles must be followed in conformity with the requirements of this chapter. Otherwise the heater may not work normally or safety problems may occur.

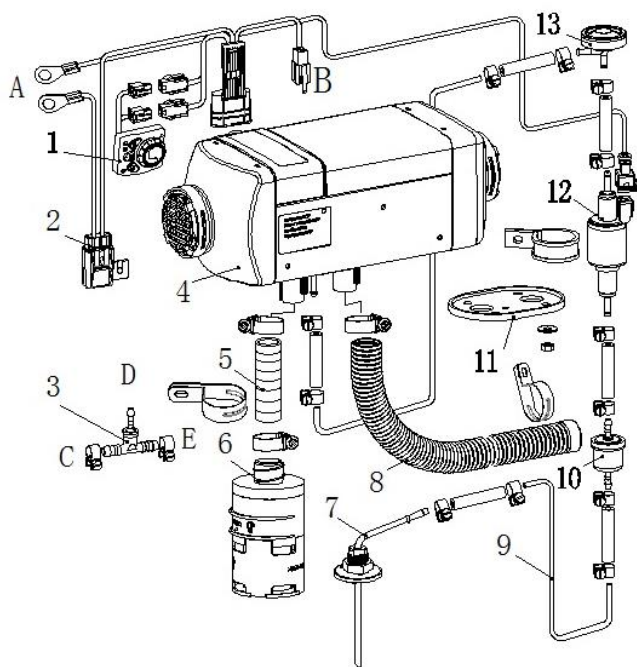

Fig. 7

1- Control switch 2- Fuse holder 3- Reducing T 4-Heater 5- Air inlet pipe
6-Air filter(optional choice) 7-Fuel suction pipe 8- Exhaust pipe 9- Fuel pipe
10-Filter 11-Gasket 12- Fuel pump 13- Damper

A Connect with battery

B Connect with external temperature sensor

C Connect with fuel tank

D Connect with heater

E Connect engine

4.1 Requirements for Installation and Places of Application of the Heater

4.1.1 It is not allowed to use the heater in locations with inflammable or explosive substances such as flammable gas or flammable dust.

4.1.2 It is not allowed to use the heater in closed space (such as garage or maintenance workshop without air ventilation) to avoid danger of poisoning due to exhaust from burning.

Attention: Under either of the above circumstances, it is not allowed to use the heater even at the timer stand-by state or wireless remote control state.

4.1.3 It is not allowed to install and use the heater in bedrooms.

4.1.4 If the heater is installed in special-purpose vehicles (such as vehicles for dangerous goods), special rules must be followed in installing the heater.

4.1.5 Never place fuel tank, compression tank, fire extinguisher, clothes, paper, etc. near the heater or opposite to the hot air vent.

4.2 Installation of the Main Heater

Any consequences caused by not installing according our requirement we don't afford any responsibility.

4.2.1 The main heater can be installed inside the vehicle or outside the vehicle. But when it is installed outside the vehicle a shield which can prevent the damage (splash of stones) of external force (supplied by retailers). The heater can't be soaked in the water or in the rain for a long time (heater should be shut off). The heater should be operated after it is completely dried if the heater is corroded by rain and water.

If the heater is installed outside the vehicle, measures must be taken to avoid splash of water onto the heater.

4.2.2 For convenience of heating air flow and installation, maintenance of the main heater, enough space must be provided for installation. Please refer to the scope of double dot line for the space for installation, as shown in Fig. 8.

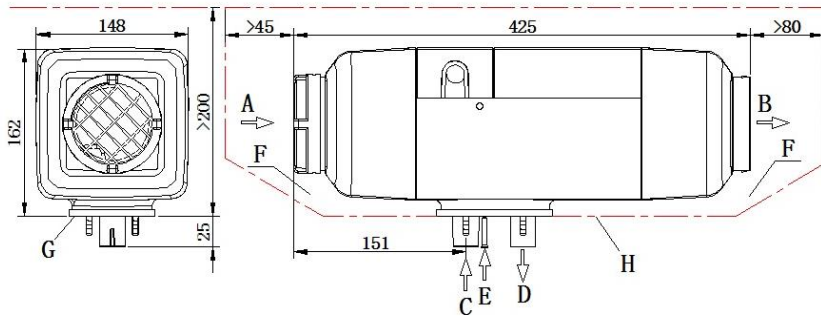

- A-Inlet of heating air B-Outlet of heated air
- C-Inlet of combustion supporting air D-Discharge of exhaust
- E-Fuel inlet F-Non-interference area G-Installation surface H-Gasket

Please make sure that there is not any foreign matter in the gap between the bottom surface of the main heater and the installation surface of the vehicle (Fig. 8-F).

4.2.3 Good sealing is necessary between the main heater and the installation surface on the vehicle. A special gasket (as shown in Fig. 8) supplied by the manufacturer must inserted in between during installation. The installation surface must be smooth and steady enough. Its parts at the installation bases of the main heater shall have unevenness of less than 1mm. After drilling installation holes, evenness must be improved according to this requirement. At installation, please rotate the four M6 nuts, which provided by the manufacturer should be tightened. The torque for tightening shall be $6\text{Nm}+1\text{Nm}$.

Please refer to Fig. 9 for positions of installation holes.

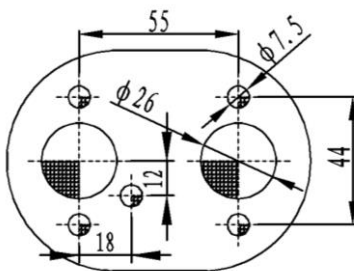

Fig. 9

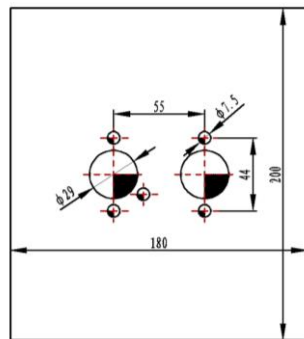

Fig.10

Attention: For re-installation of the main heater, a new gasket must be used to replace the old one.

4.2.4 If the sickness of the installation panel $< 1.5\text{mm}$ a mounting plate may

need. Between mounting plate and the car body must also be sealed (use glass glue)(Fig.10).

4.2.5 Direction for installation of the main heater is shown in Fig.11. Attention must be paid to that the inclination angle (A for gasoline heater, B for diesel heater) shall not exceed the limit showed in Fig.11, or normal operation will be affected.

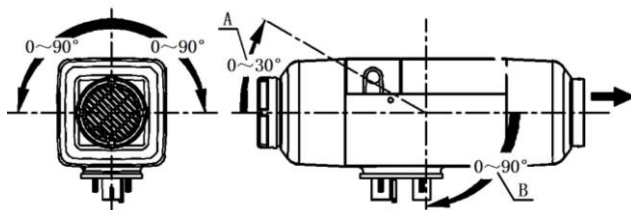

Fig.11

4.2.6 After installation of the main heater, please check and make sure that there is not any contact or friction between the blade wheel of fan and other nearby parts to avoid unsmooth operation.

4.3 Installation of Air Heating System

4.3.1 The independent outer circulation or inner circulation mode of heater can be recommended. If the air heating system of the heater have to be connected with the air duct of the vehicle, in order to ensure the air duct unobstructed the connection way should be analysed by the professionals.

4.3.2 When an external heating air pipe is attached to the heater, the pipe diameter shall not be smaller than 90mm. Its material shall be capable to resist temperature of 130°C.

4.3.3 The maximum pressure drop between the air inlet side and air outlet side of the air heating system shall not be greater than 0.15kPa.

4.3.4 The hot air from the heating system shall not erupt onto such parts that are unable to resist heat. In case of passenger vehicles, measures shall be taken to avoid blocking of the hot air vent by passengers. A self-provided protective net can be installed if necessary.

4.3.5 For heater working in external circulation mode, the position of air inlet port shall be proper to guaranteed that under normal operation no splash of water can enter. No water can be sucked into the heater and no exhaust from the engine can be sucked in.

4.3.6 For heater working in internal circulation, measures shall be taken to avoid re-entering of the supplied hot air into the air inlet port (as shown in Fig. 12). The inlet air shall be drawn from the cold area of the compartment, such as under the seats or berths. If no air inlet pipe is attached in this mode, an air inlet hood with grids (Fig. 4-6) must be installed at the air inlet port of the main heater.

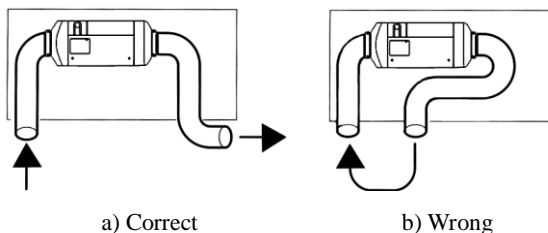

Fig. 12

4.3.7 The optional air duct fittings

Users can choose the air duct fittings in table 3 according to the situation. Please refer to Fig.13. Specification of $\Phi 60$ can only use for branch pipe.

Table 3

No.	Name	Specification
A	Grill	$\Phi 90$
		$\Phi 60$
B	Diameter changes joint	$\Phi 89/85$
		$\Phi 90/60$
		$\Phi 60/56$
C	Elbow	$\Phi 90/90^\circ$
		$\Phi 60/90^\circ$
D	Clamp	$\Phi 80 \sim 100$
		$\Phi 50 \sim 70$
E	Ducting	$\Phi 90/\Phi 95$
		$\Phi 60/\Phi 64$
F	Connector	$\Phi 90 - \Phi 90$
		$\Phi 60 - \Phi 60$
G	Reducing T	$\Phi 90$
		$\Phi 60$

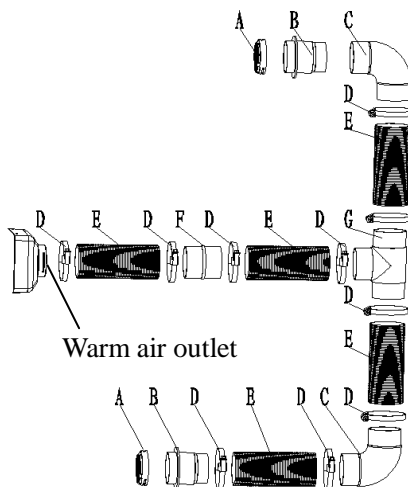

Fig. 13

4.4 Installation of Fuel Supply System

The fuel supply system for the heater is as shown in Fig. 14.

1. Fuel tank
2. Fuel extractor
3. Fuel pipe connector
4. Filter
5. Fuel pipe
6. Fuel pump
7. Damper

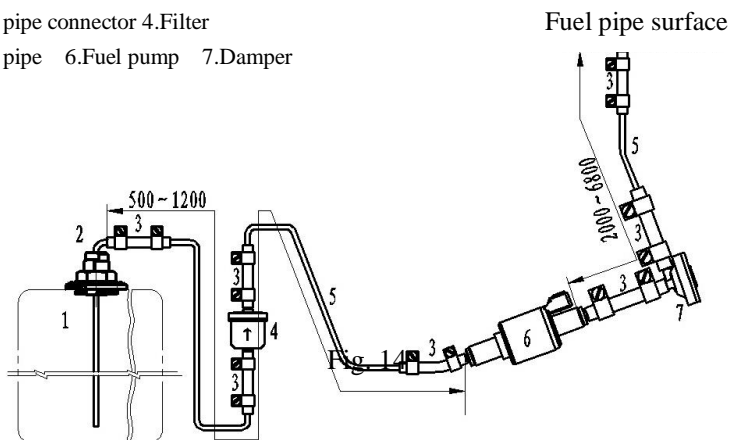

Fig.14

4.4.1 The fuel pump shall be fixed in automobile with a fuel pump clamp with protective rubber cover. The outlet of the fuel pump shall tilt upwards. The tilt angle can be selected from the range of $15^{\circ} \sim 35^{\circ}$ (as shown in Fig. 15). When conditions permit, the fuel pipe between the fuel pump and the heater shall go up gradually.

4.4.2 Damper installation should be according to the practical situation. If the packing list doesn't include the damper then it should not be used temporarily.

4.4.3 Difference in elevation between the level of fuel and the fuel pump as well as the difference in elevation between the fuel pump and the fuel inlet of the heater can produce pressure (or suction) in the fuel pipeline (See Fig. 15). So, these dimensions shall conform to the requirements as follows: $a \leq 3\text{m}$ $b \leq 0.5\text{m}$ (Avoid of negative pressure may be produced in sealed fuel tank. In such case, $b \leq 0.15\text{m}$) $c \leq 2\text{m}$.

Note:

1. Please check the vent on the fuel tank when doing installation.
2. Fuel pipe after clipping (must use blade, Scissors or pliers are forbidden) should ensure not affect fuel flow amount.

Any consequences caused by not installing according our requirement we don't afford any responsibility.

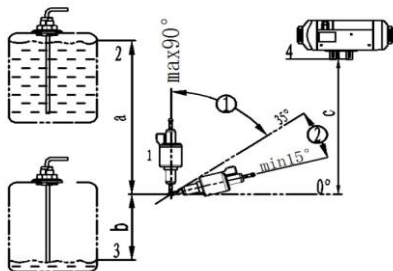

- 1-Fuel pump
- 2-Max.fuel level
- 3-Min.fuel level
- 4-Fuel inlet level

- ① Allowable installation angle
- ② Optimum installation angle

Fig. 15

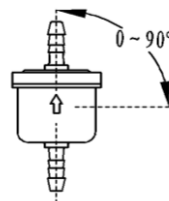

Fig.16

4.4.4 Installation of Fuel Filter

A fuel filter shall be installed before the fuel inlet port. Please make sure that the fuel flow is correctly followed.

Its position shall be in conformity with Fig. 16.

Fuel filter should be changed after 2 years, fuel pipe and clamps should also be changed.

4.4.5 Installation of Fuel Pipe

4.4.5.1 Only the flexible nylon pipe, which has good light-resistance and thermal stability, supplied with the heater can be used as the fuel pipe. The inner diameter of the pipe is $\Phi 2\text{mm}$.

4.4.5.2 The place for installation of fuel pipe shall be resistant against flying stones and shall be away from any heat emitting parts of the vehicle. Protective device can be installed if necessary.

4.4.5.3 The fuel pipe from the fuel pump to the main heater shall be in any directions other than downward direction. The fuel pipe shall be tied in some proper location to make it fixed. The distance between two ties shall be less than 50cm.

4.4.5.4 The fuel pipe fittings supplied with the heater shall be used for connections between fuel pipe and fuel pump, fuel pipe and heater, fuel pipe and sucking pipe of fuel tank and fuel pipe and reducing T. The fuel pipe shall ties with fuel pipe clamps. Bubbles shall be eliminated from the connecting places (Fig. 17).

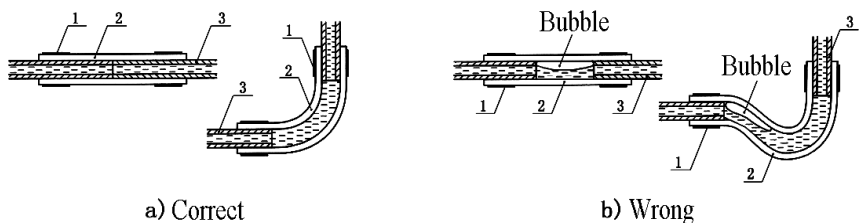

Fig. 17

1-Fuel pipe clamp; 2-Fuel pipe fitting; 3-Fuel pipe

4.4.6 Installation of Fuel Sucking Device

4.4.6.1 When fuel is sucked from the vehicle fuel tank or from an independent fuel tank, a sucking pipe shall be used. Attention shall be paid to that the openings on the fuel tank (or tank cover) for installation shall be size $\phi 25 \pm 0.2$, with trimmed brim and with good evenness around the opening. Good sealing is necessary for the base of the fuel sucking pipe. The bottom end of the fuel sucking pipe shall be 30mm-40mm from the bottom of fuel tank to suck enough fuel and at the same time to avoid sucking in impurities sediment on the bottom of fuel tank. (Fig. 18)

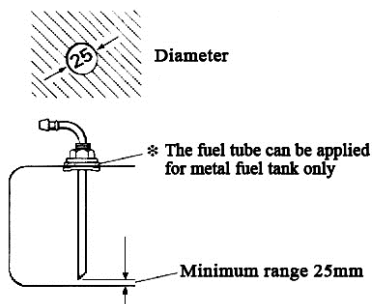

Fig. 18

4.4.6.2 If fuel is sucked from the fuel pipe to the engine, the fuel pipe from the fuel tank to the fuel filter shall be disconnected and re-connected with the thicker pipes of the reducing T and the thinner pipe of the reducing T shall connect the fuel pump of the heater via oil pipe fitting and fuel pipe. Must ensure fuel extraction without any pressure and extract the fuel smoothly when the car is stopping. The angle for installation must be in conformity with Fig. 19, or normal work of the heater will be affected.

After installation, the vehicle engine shall be started and then turned off after one minute's work to eliminate air trapped in the fuel sucking pipe.

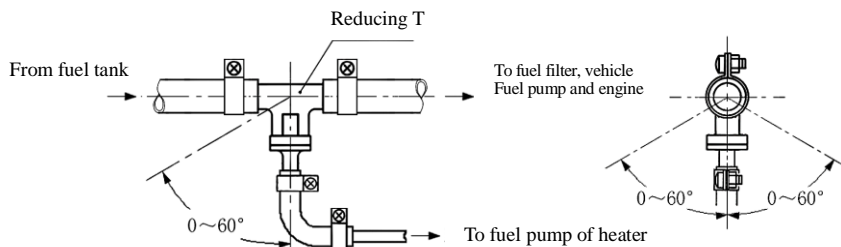

Fig. 19

4.5 Installation of Electrical System

4.5.1 The wiring diagram for the heater is shown in Fig. 20. The wires of the main heater for connection to outside circuits have been made into wire bundles. They can be laid according to the positions of various components and shall be fixed in some proper locations. The distance between two fixing points shall not exceed 30cm. Attention: Any exposed wire bundle out of the vehicle body or out of the wiring groove must be protected by corrugated pipe.

4.5.2 Connection of the main wire bundle with the heater: Use a blunt tool to pry the places marked “@” gently to remove the junction box cover (Fig. 4-1). Connect the 18-wire connector X6 of the wire bundle to the controller socket. The wire bundle can come out from either the right side or the left side of the heater. Then replace the junction box cover. Make sure to have good sealing between the junction box cover and upper cover and between the junction cover box and the wire bundle sealing mat to avoid any thermal malfunction due to leak of air from the hood-shape case.

4.5.3 Insert sheet fuse into fuse holder F and replace the upper cover tightly. Use screws to fix it in a proper location in the vehicle.

4.5.4 Connect the 2.5mm² red wire and the 2.5 brown wire (users can use their own suitable terminals) in the wire bundle to the hole terminals with springs and therefore connect to the “+” and “-” terminals of the vehicle battery.

Attention: Above parts even if not use, terminals should also be inserted into socket for future upgrade in the meantime to prevent short circuit.

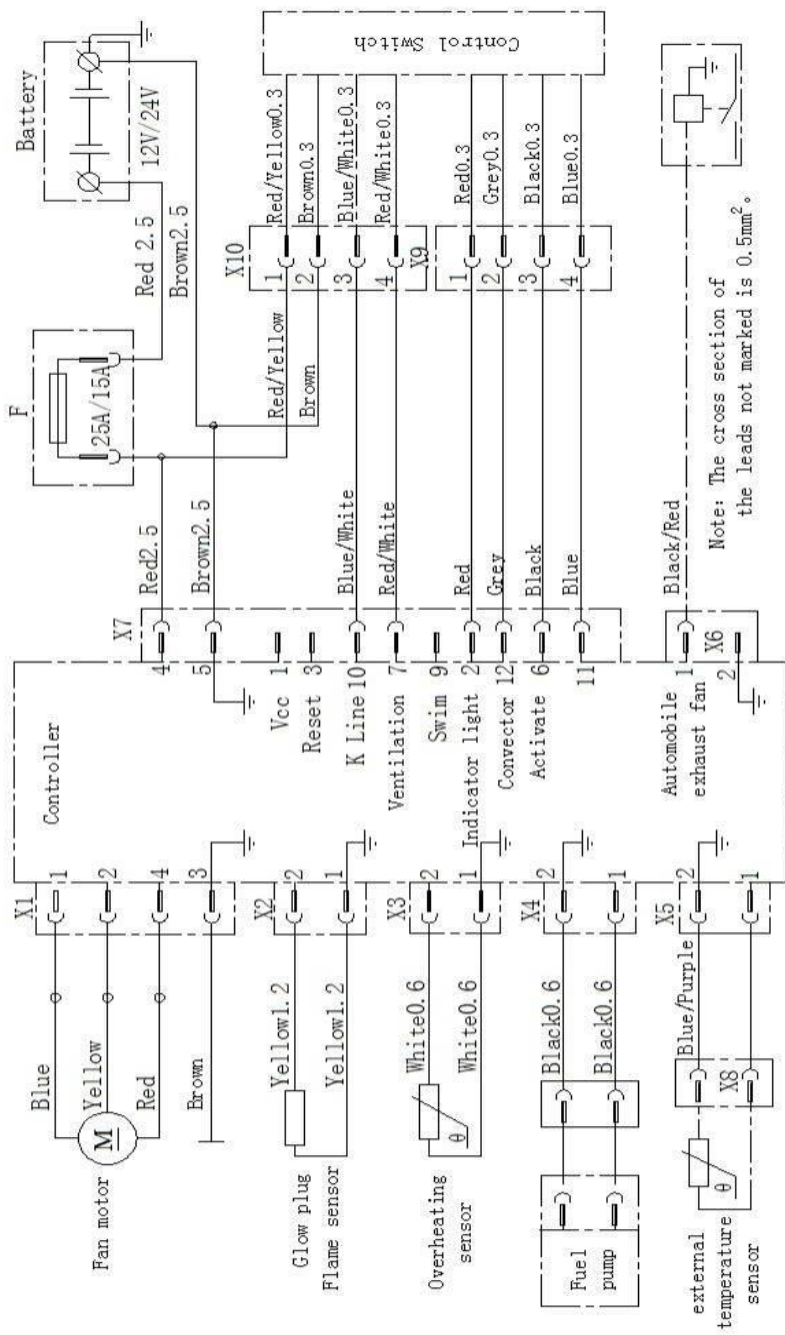

Fig.20

4.5.5 Straighten the fuel pump leads (two 0.6mm² black wires) with their protective pipes, which is made a coil inside the combustion supporting air inlet port, and put them through the opening on the wall of the air inlet pipe. Insert the terminals at the end of the wires with pressed springs into the socket of the fuel pump connector and therefore connect to the fuel pump.

4.5.6 Use four self-tapping screws to fix the control switch in a position for convenient operation and the arrangement shall make easy observation on the indicator on the case, so as to identify the working conditions (operation/stop) of the heater easily. The plug on the leads from the control switch connect with self-locking mechanism to connector X9 on the main wire bundle.

4.5.7 The surplus wires in the wire bundle at the moment are wires for function expansion. They shall be kept in good condition. Their ends shall be wrapped with electrician's insulating tape to avoid short-circuit or earthing.

4.6 Installation of Combustion Supporting Air Sucking Pipe and Exhaust Discharge Pipe.

4.6.1 The combustion supporting air must be sucked in from external fresh air outside the vehicle. The exhaust from combustion must be discharged into the air through exhaust pipe. Measures must be taken to avoid the exhaust from re-entering the vehicle.

The pipes go through the outer wall or holes on the bottom of vehicle. Measures must be taken to prevent entering of splash water. The pipes must be protected and can resist shock permanently.

4.6.2 Only the air inlet pipe and exhaust pipe provided with the heater can be used. The air inlet pipe is made with two corrugated aluminum pipes, one inside the other. The exhaust pipe is corrugated stainless steel pipe. Please identify air inlet pipe and exhaust pipe and do not make mistake at installation. To connect them with the heater, please use the supplied clamps to fix them tightly on the combustion supporting air inlet and exhaust pipe vent respectively. The protective hood on the vents of the air inlet pipe and exhaust pipe must be kept in good condition. Do not damage them or remove them.

In order to meet the dust environment, an optional air filter is a good choice(Fig.21). A length of air filter can be cut in order to meet different thickness of air inlet pipes.

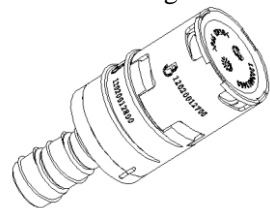

Fig.21

4.6.3 Both the air inlet pipe and exhaust pipe shall come outwards and downwards from the heater (Fig. 22), otherwise a $\Phi 5\text{mm}$ hole shall be prepared at the bottom of the pipe for discharge of condensation water. Also, the sum of all curve angles for each pipe shall not exceed 270° .

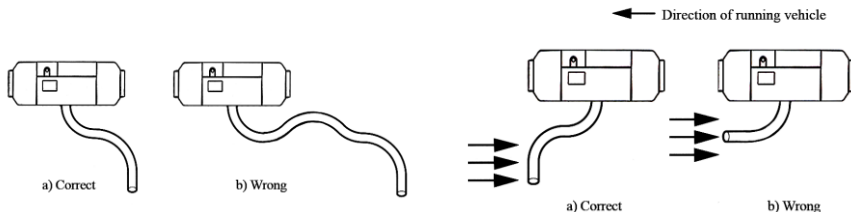

Fig. 22

Fig. 23

4.6.4 The openings of the pipes shall not be opposite to the direction of the running vehicle. (Fig. 23)

4.6.5 Arrangement of the pipes shall protect the pipe openings from blocking by slurry, rain and snow or other dirt. (Fig. 24)

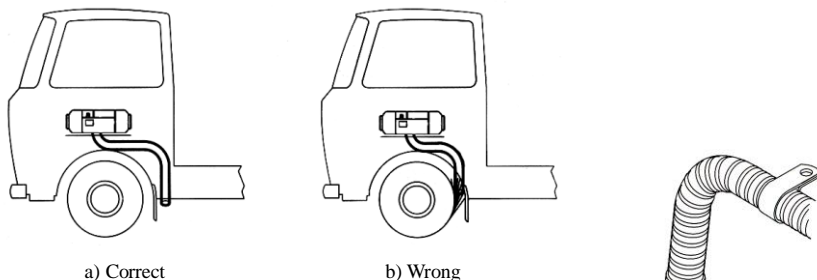

Fig. 24

Fig. 25

4.6.6 When the heat is working, the exhaust pipe is at high temperature. In installation, make sure to install it in far distance from plastic parts or other objects with poor thermal resistance of the vehicle body. The exhaust pipe shall be properly fixed. The exhaust vent shall be downwards, perpendicular to road surface with an angle of $90^\circ \pm 10^\circ$. To ensure such an angle, the fixing clamp for the exhaust pipe shall be within 150mm from the pipe end. (Fig. 25)

Warning: Violation against the above requirements may cause fire.

Any consequences caused by not installing according our requirement we don't afford any responsibility.

4.6.7 If the section of the exhaust pipe inside the vehicle may be touched by passenger, a protective cover has to be installed to prevent human contact and scald.

Air inlet pipe and exhaust pipe are easy to freeze in the use process and should be checked frequently.

5 Methods of Operation

5.1 The heater control with four ways

- (1) Use the control switch(normal configuration).
- (2)Control with extended function which use digital control switch(optional choice).
- (3)Control with extended function which use remote controller or GSM mobile phone controller(optional choice).
- (4)Control with extended function which use GSM mobile phone controller(optional choice).

5.2 Use the control switch

5.2.1 Start the heater

Turn the control knob clockwise and the power is on the controller and the work indicator (green LED) comes to light. At this moment, the heater comes to the start stage. The controller will run heating program according to the temperature control target set by the control knob. In the start stage, the time delay from switch-on to fuel supply to the fuel pump is 45 seconds.

5.2.2 Power control

After the combustor is ignited, if you want to regulate the heating temperature or the heater power, you can turn the control knob according to the arc mark around the control switch.

5.2.2.1 Constant temperature mode

When the mode indicating light turns red,the heater is in constant temperature mode.If you want to adjust the heating temperature,press the curve sign on the control switch,turn the control knob,press the mode-transformation button,mode indicating light turns green,then the heater will convert to the constant power mode.

5.2.2.2 Constant power mode

When the mode indicating light turns green,the heater is in constant power mode.If you want to adjust the power, press the curve sign on the control switch,turn the control knob,press the mode-transformation button,mode incating light turns red,the heater will convert to the constant temperature mode.

5.2.3 Ventilation mode

The user can install a ventilation switch oneself ,if you want the heater

work for air circulation only under normal temperature without any heating, you can close the ventilation switch. The wind capacity can be continuously regulated with the control knob.

5.2.4 Shutdown

If you want to turn off the heater manually, turn the knob anticlockwise to position “0”, 3 seconds after, the work indicator goes out. If the fuel pump is at work before the heater is turned off, the pump will shut down immediately. But the fan will continue to run for 180 seconds.

5.2.5 Use any other way shut off the heater (cut off the power) directly is not allowable.

5.3 Digital control switch (Optional device, see Fig.26)

Display set temperature

Set heat starting time

Set heat time

Display fault information

Eliminate fault code

Digital display power level

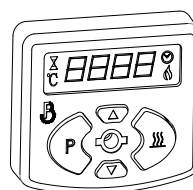

Fig.26

5.4 Remote controller (See Fig.27)

Power on and power off heater, three times

Can be set: 15mins, 30mins and 45mins immediately.

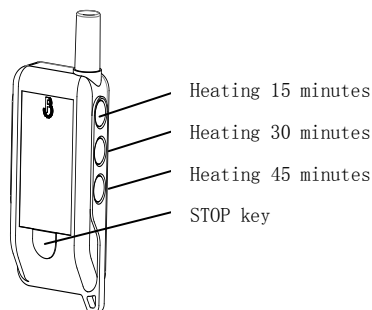

Fig.27

5.5 GSM remote controller (Fig.28)

GSM remote controller is an extended function device of parking heaters which can be started and stopped through voice and SMS by phones or cellphones. It can start and power off heater immediately.

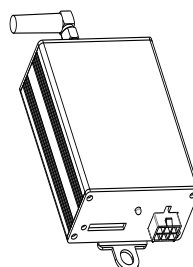

Fig.28

Operation methods for digital control switch,remote controller and GSM controller(All of this three parts are optional) please see relevant instructions.

6 Treatment of Usual Troubles

6.1 During use, the heater may become unable to start normally or die out after start. Such troubles may lead to locking state. In such case, you can turn the control knob anticlockwise to position “0” and turn off the heater and keep it in such state for at least 5 seconds. Then, restart the heater.

6.2 Circuit troubles may be caused by different reasons, such as corrosion of connectors, poor contact of connectors, wrong connection of wires, corrosion of wires or fuse, corrosion of battery poles, etc. Users need to check and prevent such troubles and offer good maintenance.

6.3 The reasons for the troubles to the heater can be indicated by the green LED on the control switch (see Section 3.3.3 for details). When the following troubles occur, users can take measures to solve:

(a)Failure to turn on the heater and the LED, the reason is open0circuit of fuse or wrong connection of wires.

(b)The heater runs idly and no start process occurs after the heater is powered on, this indicates that the temperature of air inlet (or the ambient temperature around the external temperature sensor) is higher than the set heating temperature, or called hot start. In such case, you need to turn the control switch knob clockwise to have a higher set temperature.

(c)When the LED flashes once, troubleshooting can be solved by the methods list in table 4.

Table 4

Times of flashes of LED	Troubleshooting methods
1	a Check whether the fuel pipe is blocked or whether the fuel in the tank is sufficient. b Check whether the exhaust pipe is blocked. c Check whether fuel mass is appropriate.
2	a Ditto b Ditto c Ditto d Replace the fuel pump
3	a Abnormal voltage,if the voltage is very low, then battery should be charged.
4	a Use ventilation mode cooling if temperature overhigh. b Or replace controller.
6	a Replace controller
7	a Check whether fuel pump lead connection is reliable. b Replace fuel pump.c Replace controller.
8	a Check whether the fan wheel have any scrape. b Replace fan motor assembly.c Replace controller.
9	a Clean the carbon deposition of glow plug. b Replace glow plug.c Replace controller.
10	a Whether air inlet and outlet are blocked. b Whether junction box cover tightly. c Whether inlet air and exhaust air short circuit.
11	a Check overheat sensor (normal temperature resistance is about $1k\ \Omega$). b Replace overheat sensor.
12	a Check control switch connection. b Replace control switch.
13	a Need to clean up the carbon deposition and maintenance work.

6.4 If the LED flashes for the number of times that are not mentioned above, the reasons for the troubles are complicated. Users are not capable for their solution. The problems shall be checked and solved by the service stations authorized by the manufacturer.

7 Precautions

7.1 After the heater is installed, in order to remove air trapped in the fuel supply system thoroughly and fill the fuel route with fuel only we Specially designed for oil pump function alone:In the Ventilation mode, short connection external temperature sensor 3 times continuously,then the fuel pump (4hz) stop pump fuel after the fourth time.Only effective when each power on.

7.2 Trial operation is necessary for the heater before it is put into normal use. At trial operation, you have to check leakage from all connections and all safety issues. If discharge of dense smoke is observed or irregular combustion noise or fuel smell is sensed, the heater must be turned off. Please take out the fuse, making the heater unable to operate. The heater can only be put into use after it is tested by qualified professionals.

7.3 Before each heating season, check shall be performed by qualified professionals for maintenance works, details as follows:

(a)Check air inlet and air outlet to find any pollution or foreign matters.

(b) Clean the external of the heater.

(c)Check if there is any corrosion or loose connection for electric contacts.

(d)Check to find any clogging and damage to the air inlet pipe and exhaust pipe.

(e)Check to find any leakage on the fuel pipe.

7.4 If the heater will not work for a long time, you'd better run it once every four weeks and let it run for 10 minutes at least to prevent malfunction of mechanical parts.

7.5 The air inlet port and air outlet vent of the heater must be kept clean and unblocked to provide smooth route for air flow, so as to prevent overheating.

7.6 If fuel is replaced with low-temperature fuel, run the heater for at least 15 minutes to fill new fuel into the fuel pipe and fuel pump.

7.7 When fill fuel for the heater, you have to turn off the power first. To do this, just turn the control switch anticlockwise to position “0”.

7.8 The heat exchanger of the heater can not work for longer than 10 years. When it has worked for ten years, it must be replaced with a qualified one. The replace work must be performed by the heater manufacturer or its authorized agent. At this time, the overheating sensor shall be replaced too.

7.9 The exhaust pipe of the heater for discharge of waste gas after combustion, if arranged in an area with passengers, shall be replaced with qualified one when it has worked for 10 years.

7.10 If electric welding is performed to the vehicle, please detach the positive wire of power supply of the heater from the battery and connect it to earth to protect the controller from any damage.

7.11 The ambient temperature shall be in the range of -40°C ~ 85°C for transport and storage of the heater to avoid any damage to its electronic elements and components.

7.12 Only authorized customer service stations are allowed to provide repair and installation for the heater. It is prohibited to make repair by yourself or use non-manufacturer’s parts or components so as to avoid danger.

7.13 The manufacturer shall not be held responsible for any damage to the heater if the heater is opened without authorization or such damage is caused due to installation or operation with violation against the regulations.

Packing List

No.	Name	Specification	QTY	Purchase code
1	Heater	12V Gasoline ()	1	4W200512Q02
		12V Diesel ()		4W200512C02
		24V Diesel ()		4W200524C02
2	Wiring harness		1	12030200203
3	Fuse	12V/20A ()	1	11990002000
		24V/15A ()		11990001900
4	Fuel pump	12V ()	1	33000003100
		12V with damper ()		33000007600
		24V ()		33000003200
5	Fuel pump connection wire	L=6800	1	29030000400
6	Filter	Only diesel	1	33000000400
7	Fuel pipe	φ2/φ5 L=8000	1	29030001300
8	Control switch	With gasket	1	31010700400
9	Protective cushion		1	12040600900
10	Air inlet pipe (with protective cover)	φ23/φ26 L=750	1	31010202700
11	Exhaust pipe (with protective cover)	φ22/φ28 L=700	1	31010202800
12	Gasket	81×110×2	1	12040002500
13	Reducing T	10-6-10	1	12020015700
14	Fuel pump clip	φ32	1	12010007100
15	Air inlet(Exhaust) pipe clip	Φ24/φ28	2	12010004400
16	Air inlet pipe fixing clip		2	29010003700
17	Exhaust pipe fixing clip		2	29010002300
18	Fuel pipe joint	φ4.1/φ10.5 L=50	6	12060003800
19	Fuel pipe clip	φ9/φ11 (10)	12	12010004200
20	Fuel pipe clip	φ12/φ14	2	12010004600
21	Washer	φ6/φ18	4	12010006500
22	Nut	M6	4	12050003400
23	Self drilling tapping screw	ST5.5×25	4	12050003100
24	Self drilling tapping screw	ST5.5×30	1	12050003000

Packing List (continued)

No.	Name	Specification	QTY	Purchase code
25	Self tapping screw	4×16	1	12050002700
26	Self tapping screw	3×20	1	12050002500
27	Cable ties	4×200	10	21990000000
28	Oil suction pipe	XYG-II φ5*600	1	31000000500